

USER GUIDE AND SPECIFICATIONS

NI USB-9265

4-Channel, 0–20 mA, 16-Bit Analog Current Output Module

This user guide describes how to use the National Instruments USB-9265 and lists the device specifications.

Introduction

The NI USB-9265 consists of two components: an NI 9265 module and an NI USB-9162 carrier, as shown in Figure 1.

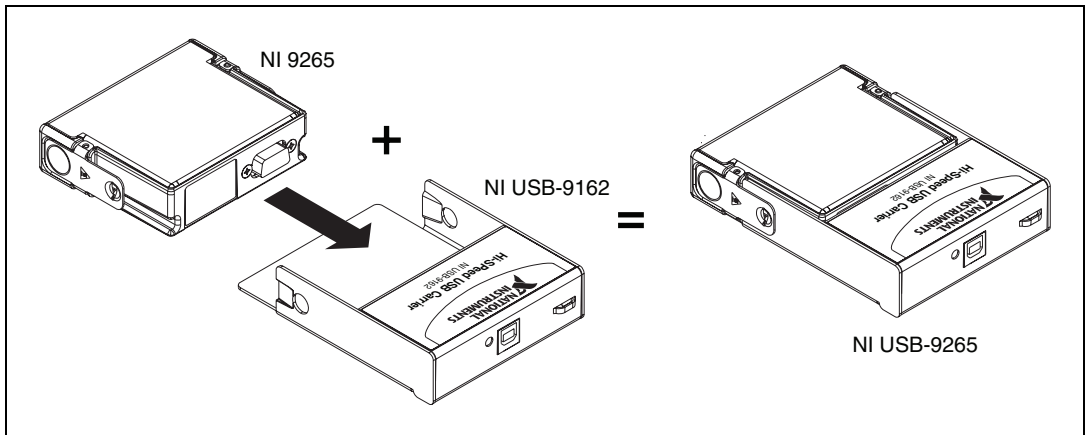

Figure 1. NI USB-9265 Components

Dimensions

Figure 2 shows the NI USB-9265 device dimensions.

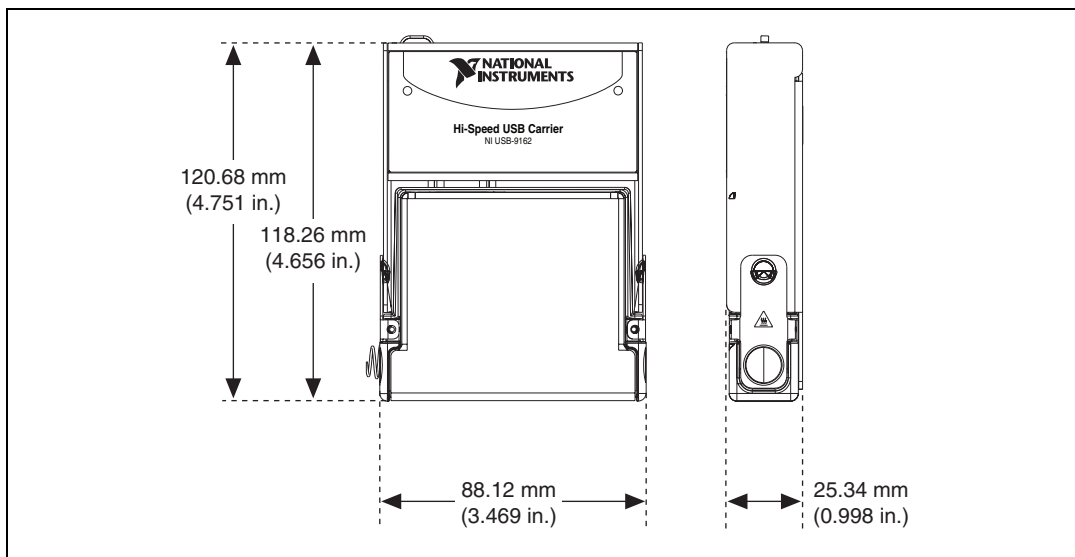

Figure 2. NI USB-9265 Device Dimensions in Millimeters (Inches)

Safety Guidelines

Operate the NI USB-9265 only as described in this user guide.



Hot Surface This icon denotes that the component may be hot. Touching this component may result in bodily injury.

Safety Guidelines for Hazardous Voltages

A hazardous voltage is a voltage greater than $42.4 V_{pk}$ or 60 VDC to earth ground. If hazardous voltages are connected to the module, take the following precautions.



Caution Ensure that hazardous voltage wiring is performed only by qualified personnel adhering to local electrical standards.



Caution Do *not* mix hazardous voltage circuits and human-accessible circuits on the same module.



Caution Make sure that devices and circuits connected to the module are properly insulated from human contact.



Caution When module terminals are hazardous voltage LIVE ($>42.4 V_{pk}/60 \text{ VDC}$), you must ensure that devices and circuits connected to the module are properly insulated from human contact. You must use the NI 9932 connector backshell kit, illustrated in Figure 3 to ensure that the terminals are *not* accessible.

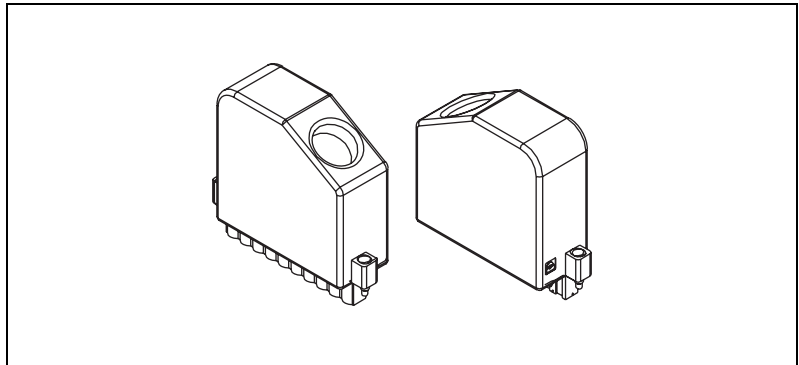

Figure 3. NI 9932 Connector Backshell

Related Documentation

Each application software package and driver includes information about writing applications for taking measurements and controlling measurement devices. Check ni.com/manuals for the most recent hardware documentation, and refer to Table 1 for a list of locations for driver and application software documentation. The following document location references assume you have NI-DAQmx 8.9 or later, and where applicable, version 7.1 or later of the NI application software.

Table 1. Related Documentation

Software	Document/Description	Location/Topic
NI-DAQmx for Windows	<p><i>DAQ Getting Started Guide</i>—describes how to install the NI-DAQmx for Windows software, your NI-DAQmx supported DAQ device, and how to confirm that your device is operating properly.</p>	<p>Start»All Programs»National Instruments»NI-DAQ»DAQ Getting Started Guide</p>
	<p><i>NI-DAQ Readme</i>—lists which devices are supported by this version of NI-DAQmx.</p>	<p>Start»All Programs»National Instruments»NI-DAQ»NI-DAQ Readme</p>
	<p><i>NI-DAQmx Help</i>—contains general information about measurement concepts, key NI-DAQmx concepts, and common applications that are applicable to all programming environments.</p>	<p>Start»All Programs»National Instruments»NI-DAQ»NI-DAQmx Help</p>
LabVIEW	<p><i>Getting Started with LabVIEW</i>—describes the LabVIEW graphical programming environment and the basic LabVIEW features you use to build data acquisition and instrument control application.</p>	<p>Start»All Programs»National Instruments»LabVIEW»LabVIEW Manuals or navigate to the labview\manuals directory and open LV_Getting_Started.pdf</p>
	<p><i>LabVIEW Help</i>—provides information about LabVIEW programming concepts, step-by-step instructions for using LabVIEW, and reference information about LabVIEW VIs, functions, palettes, menus, and tools.</p>	<p>Help»Search the LabVIEW Help</p>

Table 1. Related Documentation (Continued)

Software	Document/Description	Location/Topic
<i>LabVIEW Help Topics Specific to NI-DAQmx</i>		
Location	Description	
From the Contents tab, Getting Started»Getting Started with DAQ	Includes overview information and a tutorial to learn how to take an NI-DAQmx measurement in LabVIEW using the DAQ Assistant.	
From the Contents tab, VI and Function Reference» Measurement I/O VIs and Functions	Describes the LabVIEW NI-DAQmx VIs and properties.	
From the Contents tab, Taking Measurements	Contains the conceptual and how-to information you need to acquire and analyze measurement data in LabVIEW, including common measurements, measurement fundamentals, NI-DAQmx key concepts, and device considerations.	
LabWindows™/CVI™	<i>LabWindows/CVI Help Data Acquisition</i> book—contains NI-DAQmx measurement concepts and step-by-step instructions about creating a measurement task using the DAQ Assistant.	Help»Contents , then select Using LabWindows/CVI» Data Acquisition»Taking an NI-DAQmx Measurement in LabWindows/CVI
	<i>LabWindows/CVI Help NI-DAQmx Library</i> book—contains NI-DAQmx API overviews and function reference.	LibraryReference» NI-DAQmx Library
Measurement Studio/ Microsoft Visual Studio .NET	<i>Microsoft Visual Studio .NET Help/NI Measurement Studio Help</i> —contains NI-DAQmx methods and properties.	Measurement Studio» NI Measurement Studio Help and select NI-DAQmx .NET Class Library or NI-DAQmx Visual C++ Class Library
ANSI C without NI Application Software	<i>NI-DAQmx Help</i>	Start»All Programs» National Instruments» NI-DAQ»NI-DAQmx Help
	<i>NI-DAQmx C Reference Help</i> —describes the NI-DAQmx Library functions.	Start»All Programs» National Instruments» NI-DAQ»NI-DAQmx C Reference Help

Table 1. Related Documentation (Continued)

Software	Document/Description	Location/Topic
.NET Languages without NI Application Software*	<i>NI-DAQmx .NET Help</i> —contains conceptual topics for using NI-DAQmx with Visual C# and Visual Basic .NET.	Start»All Programs»National Instruments»NI-DAQ»NI-DAQmx .NET Reference Help. Expand NI Measurement Studio Help»NI Measurement Studio .NET Class Library»Reference to view the function reference. Expand NI Measurement Studio Help»NI Measurement Studio .NET Class Library»Using the Measurement Studio .NET Class Libraries
	<i>Visual Studio .NET Help</i> —contains conceptual topics for using NI-DAQmx with Visual C# and Visual Basic .NET.	Help»Contents. Select Measurement Studio from the Filtered By drop-down list and follow the location instructions for the <i>NI-DAQmx .NET Help</i> .
* With the Microsoft .NET Framework version 1.1 or later, you can use NI-DAQmx to create applications using Visual C# and Visual Basic .NET without Measurement Studio. You need Microsoft Visual Studio .NET 2003 or Microsoft Visual Studio 2005 for the API documentation to be installed.		

Device Documentation and Specifications

Check ni.com/manuals for the most recent device and software documentation. If you do not have Web access, NI-DAQmx includes a Documentation CD that includes documentation available when NI-DAQmx released.

Training Courses

If you need more help getting started developing an application with NI products, NI offers training courses. To enroll in a course or obtain a detailed course outline, refer to ni.com/training.

Technical Support on the Web

For additional support, refer to ni.com/support or zone.ni.com.

Installing the Software

Software support for the NI USB-9265 for Windows Vista/XP is provided by NI-DAQmx. The *DAQ Getting Started Guide*, which you can download at ni.com/manuals, offers NI-DAQmx users step-by-step instructions for installing software and hardware, configuring channels and tasks, and getting started developing an application.

Installing Other Software

If you are using other software, refer to the installation instructions that accompany your software.

Example Programs

The NI-DAQmx media contains example programs that you can use to get started programming with the NI USB-9265. Refer to the *NI-DAQmx for USB Devices Getting Started Guide* that shipped with your device, and is also accessible from **Start»All Programs»National Instruments»NI-DAQ**, for more information.

Mounting the NI USB-9265 to a Panel

Threaded inserts are located in the NI USB-9162 for mounting it to a panel. Mount the USB-9162 carrier before inserting the NI 9265. Refer to Figure 4 for dimensions.

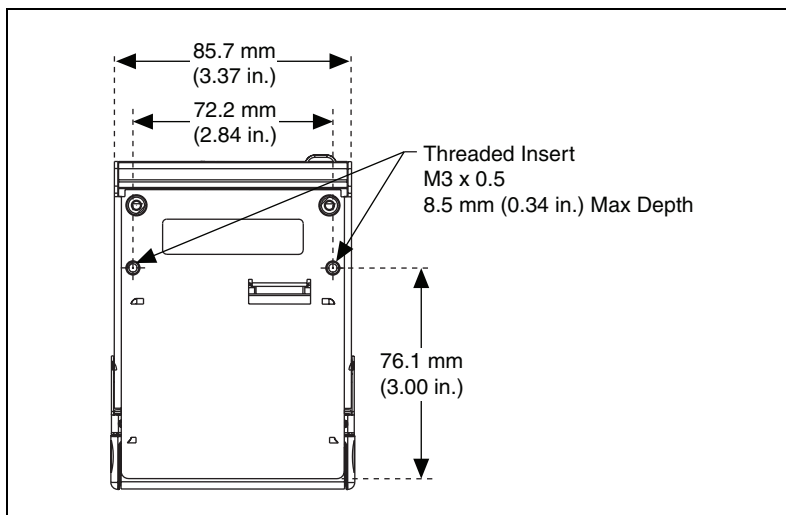

Figure 4. Module Mounting Dimensions In Millimeters (Inches)

Installing the NI USB-9265 Device

Before installing the device, you must install the software you plan to use with the device. Refer to the [Installing the Software](#) section of this guide and the documentation included with the software for more information.

Installing the NI 9265 into the NI USB-9162 Carrier

The NI 9265 C Series module and NI USB-9162 carrier are packaged separately. Refer to Figure 5 while completing the following assembly steps:

1. Make sure that no signals are connected to the NI 9265 module, and the USB cable is not attached to the USB-9162 carrier.
2. Remove the protective cover from the 15-pin D-SUB connector.
3. Align the I/O module with the carrier, as shown in Figure 5.

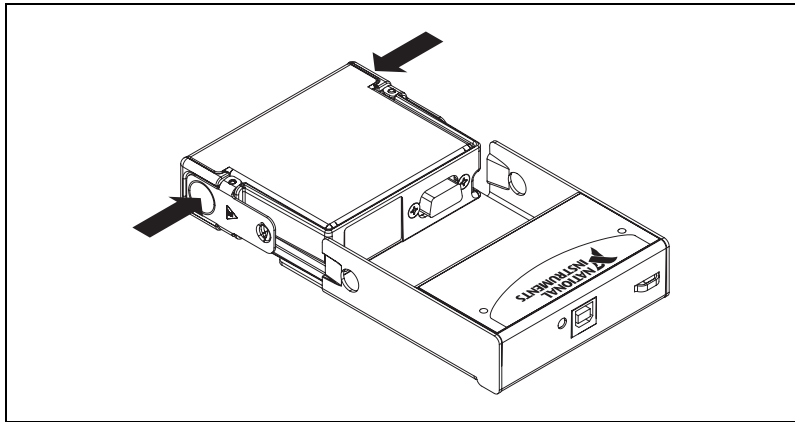

Figure 5. Module Installation

4. Squeeze the latches and insert the NI 9265 module into the NI USB-9162 carrier.

- Press firmly on the connector side of the NI 9265 module until the latches lock the module into place, as shown in Figure 6.

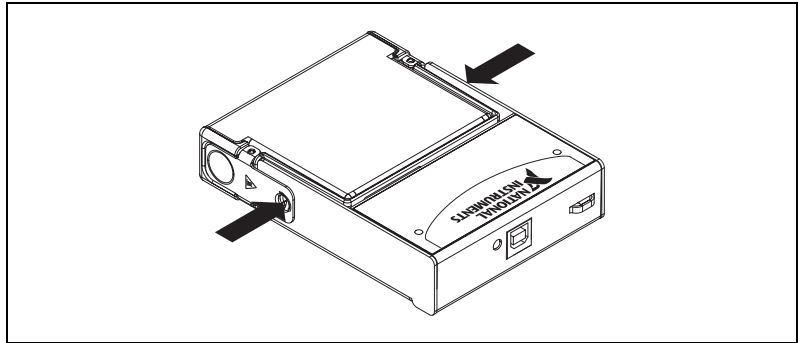

Figure 6. Locking Module into Place

Connecting the NI USB-9265 to a Computer

Plug one end of the USB cable into the NI USB-9265 and the other end into an available USB port on the computer. Refer to the *NI-DAQmx for USB Devices Getting Started Guide* that shipped with your device, and is also accessible from **Start»All Programs»National Instruments»NI-DAQ**, for more information.

LED Indicator

The NI USB-9265 device has a green LED next to the USB connector. The LED indicator indicates device status, as listed in Table 2. When the device is connected to a USB port, the LED blinks steadily to indicate that the device is initialized and is receiving power from the connection.

If the LED is not blinking, it may mean that the device is not initialized or the computer is in standby mode. In order for the device to be recognized, the device must be connected to a computer that has NI-DAQmx installed on it. If your device is not blinking, make sure your computer has the latest version of NI-DAQmx installed on it, and the computer is not in standby mode.

Table 2. LED State/Device Status

LED State	Device Status
Not lit	Device not connected or in suspend.
On, not blinking	Device connected, but no module installed.
Single-blink	Operating normally.

Table 2. LED State/Device Status (Continued)

LED State	Device Status
Double-blink	Operating normally.
Quadruple-blink	Device error. Refer to ni.com/support .

Wiring the NI USB-9265 Device

The NI 9265 has a 10-terminal, detachable screw-terminal connector that provides connections for four analog output channels.



Caution A high voltage screw terminal backshell must be installed when using hazardous voltages ($>42.4 V_{pk}$, 60 VDC).

You must use 2-wire ferrules to create a secure connection when connecting more than one wire to a single terminal on the NI USB-9265.

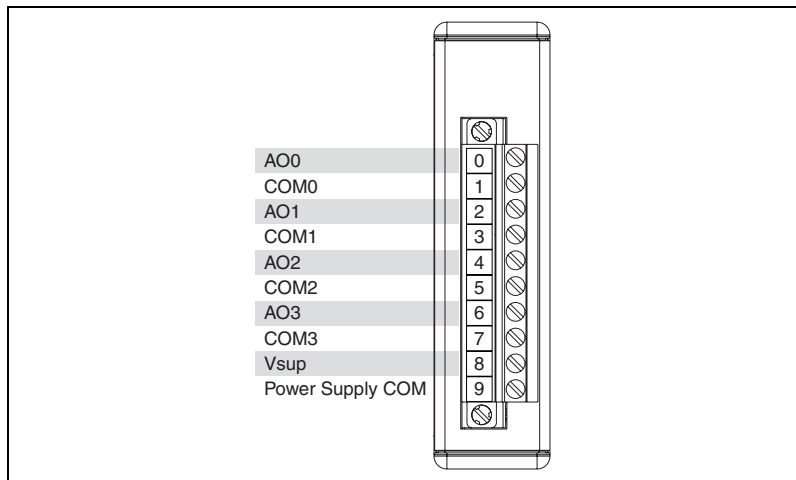

Figure 7. NI USB-9265 Terminal Assignments

The NI USB-9265 has four analog output channels, AO. Each channel has a common terminal, COM, that is internally connected to the isolated ground reference of the module. The USB-9265 also has a terminal for an external power supply, V_{sup} , and an external power supply common terminal, Power Supply COM.

Each AO channel has a digital-to-analog converter (DAC) that produces a current signal. Each channel also has overvoltage and short-circuit protection. Refer to the [Specifications](#) section for more information about the overvoltage and short-circuit protection. Refer to Figure 8 for an illustration of the output circuitry for one channel of the NI USB-9265.

You can connect a load to each channel of the NI USB-9265. Connect the positive lead of the load to the AO terminal. Connect the ground of the load to the corresponding COM terminal. Refer to Figure 8 for an illustration of how to connect a load to the NI USB-9265.

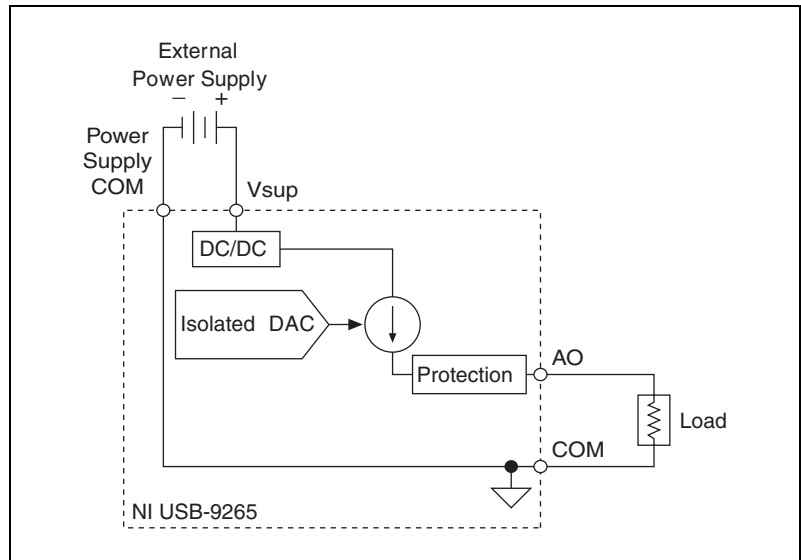

Figure 8. Connecting a Load to the NI USB-9265



Note You must use 2-wire ferrules to create a secure connection when connecting more than one wire to a single terminal on the NI USB-9265.

You must connect an external power supply to the NI USB-9265. This power supply provides the current for the devices you connect to the module. Connect the positive lead of the power supply to the supply terminal, V_{sup} , and the negative lead of the power supply to Power Supply COM.

When the module powers on, the channels output the startup current. Refer to the [Specifications](#) section for more information about startup current. Refer to the software help for information about configuring startup output states in software. Visit ni.com/info and enter `cseriesdoc` for information about C Series documentation.

Wiring for High-Vibration Applications

If an application is subject to high vibration, National Instruments recommends that you either use ferrules to terminate wires to the detachable screw-terminal connector or use the NI 9932 backshell kit to protect the connections. Refer to Figure 9 for an illustration of using ferrules. Refer to Figure 3 for an illustration of the NI 9932 connector backshell.

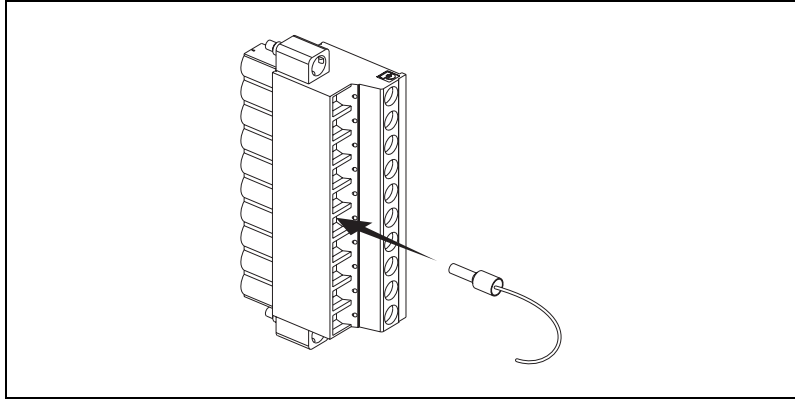

Figure 9. 10-Terminal Detachable Screw-Terminal Connector with Ferrule

Specifications

The following specifications are typical for the range -40 to 70 °C unless otherwise noted. All voltages are relative to COM unless otherwise noted.

Output Characteristics

Number of channels	4 analog output channels
DAC resolution	16 bits
Type of DAC	String
Power-on output state	0
Startup current	0.0 mA
Power-down current	0.0 mA
Full-scale output current	
Minimum	20.1 mA
Typical	20.6 mA
Maximum	21.0 mA

Output range..... 0 to 20 mA
 Compliance voltage..... 12 VDC max
 Maximum load 600 Ω

Accuracy

Measurement Conditions	Percent of Reading (Gain Error)	Percent of Range* (Offset Error)
Calibrated, typ (25 °C, ± 5 °C)	0.11%	0.19%
Calibrated, max (-40 to 70 °C)	0.25%	0.4%
Uncalibrated, typ (25 °C, ± 5 °C)	0.35%	1.4%
Uncalibrated, max (-40 to 70 °C)	0.85%	2.5%
* Range equals 0 to 20.6 mA		

Stability

Gain drift..... 30 ppm/°C
 Offset drift..... 45 ppm/°C

External power supply

voltage range (V_{sup})..... 9–36 VDC

Protection (AO, V_{sup})

Overvoltage..... ± 40 V
 Short-circuit Indefinitely

Noise 600 nA_{rms}

Crosstalk..... -90 dB

Settling time (to 1 LSB)

Full-scale step 10 μ s
 1 mA step 5 μ s

Glitch energy Unmeasurable

Monotonicity 16 bits

DNL 1 LSB max

INL ± 16 LSB

Power Requirements

Current consumption from USB.....	230 mW max
Suspend mode.....	2.5 mA, max

Bus Interface

USB specification	USB 2.0 Hi-Speed
-------------------------	------------------

Physical Characteristics

Screw-terminal wiring	12 to 24 AWG copper conductor wire with 10 mm (0.39 in.) of insulation stripped from the end
Ferrules	0.25 mm ² to 2.5 mm ²
Torque for screw terminals.....	0.5 to 0.6 N · m (4.4 to 5.3 lb · in.)
Weight	236 g (8.4 oz)

Safety

If you need to clean the module, wipe it with a dry towel.

Maximum Voltage¹

Connect only voltages that are within the following limits.

Channel-to-COM or V_{sup} -to-COM	± 40 V max
--	----------------

Isolation Voltages

Channel-to-channel.....	No isolation between channels
-------------------------	-------------------------------

Channel-to-earth ground, V_{sup} -to-earth ground,
or COM-to-earth ground

Continuous.....	250 V_{rms} , Measurement Category II
Withstand.....	2,300 V_{rms} , verified by a 5 s dielectric withstand test

Measurement Category II is for measurements performed on circuits directly connected to the electrical distribution system. This category refers

¹ The maximum voltage that can be applied between any channel or V_{sup} terminal and a COM terminal without damaging the module or other devices.

to local-level electrical distribution, such as that provided by a standard wall outlet, for example, 115 V for U.S. or 230 V for Europe.



Caution Do *not* connect the NI USB-9265 to signals or use for measurements within Measurement Categories III or IV.

Safety Standards

This product is designed to meet the requirements of the following standards of safety for electrical equipment for measurement, control, and laboratory use:

- IEC 61010-1, EN 61010-1
- UL 61010-1, CSA 61010-1



Note For UL and other safety certifications, refer to the product label or visit ni.com/certification, search by module number or product line, and click the appropriate link in the Certification column.

Environmental

National Instruments C Series modules are intended for indoor use only but may be used outdoors if installed in a suitable enclosure.

Operating temperature
(IEC 60068-2-1, IEC 60068-2-2)..... –40 to 70 °C

Storage temperature
(IEC 60068-2-1, IEC 60068-2-2)..... –40 to 85 °C

Ingress protection..... IP 40

Operating humidity
(IEC 60068-2-56)..... 10 to 90% RH, noncondensing

Storage humidity
(IEC 60068-2-56)..... 5 to 95% RH, noncondensing

Maximum altitude 2,000 m

Pollution Degree (IEC 60664) 2

Electromagnetic Compatibility

This product meets the requirements of the following EMC standards for electrical equipment for measurement, control, and laboratory use:

- EN 61326 (IEC 61326): Class A emissions; Basic immunity
- EN 55011 (CISPR 11): Group 1, Class A emissions
- AS/NZS CISPR 11: Group 1, Class A emissions
- FCC 47 CFR Part 15B: Class A emissions
- ICES-001: Class A emissions



Note For the standards applied to assess the EMC of this product, refer to the *Online Product Certification* section.



Note For EMC compliance, operate this device with shielded cabling.

CE Compliance

This product meets the essential requirements of applicable European Directives as follows:

- 2006/95/EC; Low-Voltage Directive (safety)
- 2004/108/EC; Electromagnetic Compatibility Directive (EMC)

Online Product Certification

Refer to the product Declaration of Conformity (DoC) for additional regulatory compliance information. To obtain product certifications and the DoC for this product, visit ni.com/certification, search by model number or product line, and click the appropriate link in the Certification column.

Environmental Management

National Instruments is committed to designing and manufacturing products in an environmentally responsible manner. NI recognizes that eliminating certain hazardous substances from our products is beneficial not only to the environment but also to NI customers.

For additional environmental information, refer to the *NI and the Environment* Web page at ni.com/environment. This page contains the environmental regulations and directives with which NI complies, as well as other environmental information not included in this document.



Waste Electrical and Electronic Equipment (WEEE)

EU Customers At the end of their life cycle, all products *must* be sent to a WEEE recycling center. For more information about WEEE recycling centers and National Instruments WEEE initiatives, visit ni.com/environment/weee.htm.

电子信息产品污染控制管理办法（中国 RoHS）



中国客户 National Instruments 符合中国电子信息产品中限制使用某些有害物质指令 (RoHS)。关于 National Instruments 中国 RoHS 合规性信息, 请登录 ni.com/environment/rohs_china。(For information about China RoHS compliance, go to ni.com/environment/rohs_china.)

Calibration

You can obtain the calibration certificate and information about calibration services for the NI 9265 at ni.com/calibration.

Calibration interval 1 year

Where to Go for Support

The National Instruments Web site is your complete resource for technical support. At ni.com/support you have access to everything from troubleshooting and application development self-help resources to email and phone assistance from NI Application Engineers.

National Instruments corporate headquarters is located at 11500 North Mopac Expressway, Austin, Texas, 78759-3504. National Instruments also has offices located around the world to help address your support needs. For telephone support in the United States, create your service request at ni.com/support and follow the calling instructions or dial 512 795 8248. For telephone support outside the United States, contact your local branch office:

Australia 1800 300 800, Austria 43 662 457990-0,
Belgium 32 (0) 2 757 0020, Brazil 55 11 3262 3599,
Canada 800 433 3488, China 86 21 5050 9800,
Czech Republic 420 224 235 774, Denmark 45 45 76 26 00,
Finland 358 (0) 9 725 72511, France 01 57 66 24 24,
Germany 49 89 7413130, India 91 80 41190000, Israel 972 3 6393737,
Italy 39 02 41309277, Japan 0120-527196, Korea 82 02 3451 3400,
Lebanon 961 (0) 1 33 28 28, Malaysia 1800 887710,
Mexico 01 800 010 0793, Netherlands 31 (0) 348 433 466,
New Zealand 0800 553 322, Norway 47 (0) 66 90 76 60,
Poland 48 22 328 90 10, Portugal 351 210 311 210,
Russia 7 495 783 6851, Singapore 1800 226 5886,
Slovenia 386 3 425 42 00, South Africa 27 0 11 805 8197,

Spain 34 91 640 0085, Sweden 46 (0) 8 587 895 00,
Switzerland 41 56 2005151, Taiwan 886 02 2377 2222,
Thailand 662 278 6777, Turkey 90 212 279 3031,
United Kingdom 44 (0) 1635 523545

National Instruments, NI, ni.com, and LabVIEW are trademarks of National Instruments Corporation. Refer to the *Terms of Use* section on ni.com/legal for more information about National Instruments trademarks. Other product and company names mentioned herein are trademarks or trade names of their respective companies. For patents covering National Instruments products/technology, refer to the appropriate location: **Help»Patents** in your software, the `patents.txt` file on your media, or the *National Instruments Patent Notice* at ni.com/patents.